

## AFK HD

Sistema per la preparazione rapida di Acqua Calda Sanitaria serie AFK-HD per piccole, medie e grandi comunità in grado di soddisfare elevate richieste di ACS limitando il volume di accumulo necessario.

Il sistema AFK-HD è composto da:

- scambiatore a piastre ispezionabili inox AISI 316L modello K042 o K080;
- basamento autoportante in acciaio inox con piedi di appoggio regolabili;
- pompa di ricircolo lato sanitario in acciaio inox;
- Kit raccordi flessibili pre-coibentati inox e valvole di intercettazione (optional);
- Coibentazione scambiatore rimuovibile (optional);
- Termostato per controllo circuito primario (optional);
- Quadro elettrico di controllo e comando Anti-Legionella (optional) in grado di realizzare cicli anti-legionella mediante shock termici (giornalieri o settimanali).

### ACCESSORI DISPONIBILI

A richiesta sono disponibili i seguenti accessori: kit raccordi per collegare il gruppo di scambio al serbatoio completo di tubo flessibile inox e valvole di intercettazione, coibentazione scambiatore a piastre, bi-termostato per controllo circuito primario e quadro elettrico di controllo e comando Anti-Legionella in grado di realizzare cicli anti-legionella mediante shock termici (giornalieri o settimanali), regolare la temperatura in accumulo con la possibilità di impostare set-point differenziati a seconda della fascia oraria e del giorno della settimana; comandare pompa di ricircolo sanitaria e circuito primario; comandare valvola miscelatrice su circuito primario; comandare valvola di by-pass per trattamento di shock termico su impianto sanitario dotato di regolazione termostatica.

### COMPATIBILITÀ

La serie AFK-HD può essere abbinata a tutti gli accumuli della serie TK, TK-AT, TKX,S-AT, SI-AT, L-AT ed LX.

The AFK-HD fast preparation unit is intended for the production of domestic hot water in small, medium and large-sized communities, to meet high demand of domestic hot water, while reducing the storage volume needed.

The AFK-HD system consists of:

- gasketed plate heat exchanger – AISI 316L stainless steel, model K042 or K080;
- stainless steel self-supporting base with adjustment feet;;
- stainless steel recirculation pump on tap water side;
- stainless steel, pre-insulated flexible fittings and shut-off valves (optional);
- removable insulation of heat exchanger (optional);
- thermostat for primary circuit (optional);
- anti-legionella control electric board (optional) to make anti-legionella cycles through thermal shock (daily or weekly).

### ON-DEMAND ACCESSORIES

The following accessories can be supplied on demand: fittings to connect the heat exchanger to the tank, complete with stainless steel flexible pipe and shut-off valves, plate heat exchanger insulation, double thermostat for primary circuit and anti-legionella control electric board which lets you make anti-legionella cycles through thermal shocks (daily or weekly), adjust storage temperature and set different set points based on time and day of the week, operate the domestic water recirculation pump and primary circuit, operate the mixing valve on the primary circuit, operate the by-pass valve for thermal shock treatment on DHW system complete with thermostatic adjustment.

### COMPATIBILITY

The AFK-HD series can be combined with all TK-AT, TKX,S-AT, SI-DAT, L-AT and LX storage units.



	CIRCUITO PRIMARIO / PRIMARY CIRCUIT		CIRCUITO SECONDARIO / SECONDARY CIRCUIT	
	TEMPERATURA max temperature max	PRESSIONE max pressure max	TEMPERATURA max temperature max	PRESSIONE max pressure max
AFK-HD	110°C	16 bar	95°C	6 bar



SIZE 1

SIZE 2

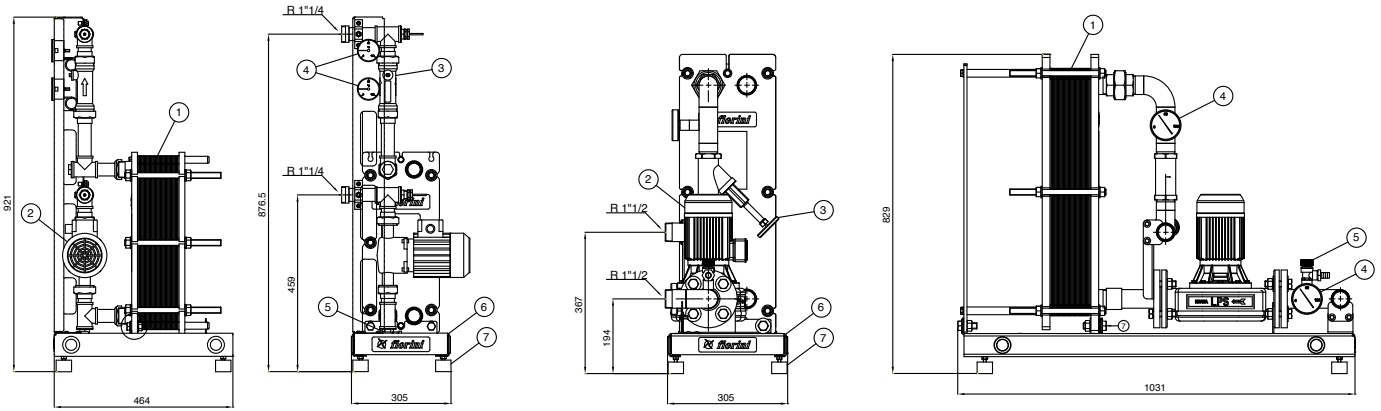

Modello Model	Scambiatore Exchanger	Potenza Power (kW)	Portata primario Primary circuit flow rate (l/h)	Pdc primario Primary circuit load loss (kPa)	Caratteristiche elettriche pompa Pump specifications		Codice Part no.
					(V/Hz/ph)	(A)	
<b>SIZE 1</b>							
AFK-HD 35	K042/09	30*/10**	1500*/1800*	18*/25**	230/50/1	1.15	841060019X
AFK-HD 70	K042/15	70*/22**	3000*/3900**	24*/40**	230/50/1	1.15	841060020X
AFK-HD 115	K042/21	110*/33**	5000*/5800**	33*/45**	230/50/1	1.15	841060021X
AFK-HD 150	K042/25	150*/39**	6500*/6800**	39*/45**	400/50/3	0.38	841060022X
AFK-HD 200	K042/33	200*/50**	8600*/8700**	39*/43**	400/50/3	0.38	841060018X
<b>SIZE 2</b>							
AFK-HD 250	K080H/23	250*/165**	8800*/8800**	49*/49**	400/50/3	1.03	841060023X
AFK-HD 300	K080H/29	300*/170**	10500*/10500**	48*/48**	400/50/3	1.03	841060024X
AFK-HD 350	K080H/33	350*/210**	12500*/12500**	47*/47**	400/50/3	1.03	841060025X
AFK-HD 400	K080H/39	400*/250**	14100*/14100**	46*/46**	400/50/3	1.03	841060026X

Elenco componenti  
List of components

- 1 Scambiatore di calore a piastre ispezionabili
  - 2 Pompa di ricircolo con girante inox
  - 3 Regolatore di portata
  - 4 Termometri
  - 5 Valvola di sicurezza
  - 6 Basamento e struttura in acciaio inox
  - 7 Piedini regolabili
- 1 Gasketed plate heat exchanger
  - 2 Flow rate regulator
  - 3 Flow rate regulator
  - 4 Thermometer
  - 5 Safety valve
  - 6 Stainless steel base and frame
  - 7 Adjustable feet

\* Primario 80°C, secondario 10/45°C \*\* Primario 55°C, secondario 10/45°C  
 \* primary circuit 80°C, secondary circuit 10/45°C \*\* primary circuit 55°C, secondary circuit 10/45°C

Erogazione di ACS in litri nei primi 10/20/60 minuti e portata in erogazione continua in l/h (Primario 80°C, erogazione 45°C)  
 Supply of DHW in litres in the first 10/20/60 minutes and flow rate in continuous supply in l/h (primary 80°C, supply 45°C)

Volume Volume	Modello								
	K042/09	K042/15	K042/21	K042/25	K042/33	K080H/23	K080H/29	K080H/33	K080H/39
200	330/500	440/725	500/1300	730/2075	810/2330	1055/1995	1340/2570	1505/2895	1830/3550
	1100/859	2000/1717	2900/2862	4150/3721	4900/4866	5765/5650	7485/7370	8465/8350	10430/10320
300	430/600	535/1200	590/1400	800/2125	880/2375	1110/2055	1400/2625	1560/2955	1890/3610
	1300/859	2000/1717	2905/2862	4200/3721	4900/4866	5820/5650	7540/7370	8525/8350	10490/10320
500	665/800	730/1475	785/1660	990/2310	1060/2560	1225/2165	1510/2740	1675/3070	2005/3725
	1500/859	2100/1717	2910/2862	4175/3721	4910/4866	5935/5650	7655/7370	8640/8350	10605/10320
800	900/1030	980/1835	1030/2025	1230/2625	1300/2860	1395/2340	1685/2910	1845/3240	2175/3895
	1750/859	2300/1717	2920/2862	4175/3721	4915/4866	6105/5650	7825/7370	8810/8350	10775/10320
1000	1130/1300	1220/2200	1280/2385	1470/300	1540/3200	1510/2455	1800/3025	1960/3355	2290/4010
	1900/859	2500/1414	2930/2862	4300/3721	4920/4866	6220/5650	7940/7370	8925/8350	10890/10320
1500	1630/1830	1725/2950	1780/3125	1965/3710	2025/3925	1795/2740	2085/3310	2245/3640	2575/4295
	2490/859	2975/1717	3350/2862	4675/3721	5150/4866	6505/5650	8225/7370	9210/8350	11175/10320
2000	2160/2300	2220/3700	2280/3860	2465/4450	2500/4650	2080/3025	2370/3600	2535/3925	2860/4580
	300/859	3450/1717	3825/2862	5100/3721	5550/4866	6790/5650	8510/7370	9595/8350	11460/10320

